



## BÜFA®-TEC DELTA EVO-LINE

Fibre Spray-, Gelcoat-, Laminating Roll- and RTM unit

# Clear Set-Up & Individual Configuration

## BÜFA®-TEC DELTA EVO-LINE

The BÜFA®-Tec Delta resin and hardener pump is a reliable and durable pump unit that will give you high performance even in the most demanding production environments. The systems are designed for a long, reliable operating life and consist of sectional modules. The modular set-up allows fast maintenance with minimal downtime. With the appropriate tools, the Delta unit can be used as a fibre spray unit, gelcoat unit, laminating roll unit or RTM unit.



09-17 | Illustrations: BÜFA, Fotolia © Vanessa, Thaut Images  
Subject to change without notification. The information given above is based on our current state of knowledge and experience. In view of the many factors that may influence processing and application of our products, the user is not relieved from carrying out his own tests and trials. No legally binding warranty of certain properties or suitability for a particular purpose can be derived from this information. It is the responsibility of the receiver or user of our products to observe proprietary rights as well as existing laws and regulations. The latest version of the EU Safety Data Sheet must also be observed. For further information and Technical Information Sheets, go to [www.buefa.de](http://www.buefa.de).

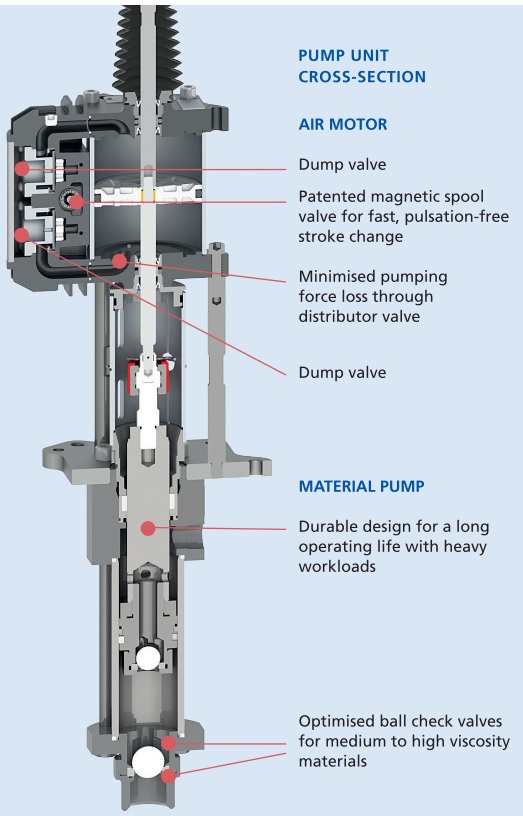

### TECHNICAL INFORMATION:

- Pressure ratio resin: 17:1
- Amount of peroxide: 1 - 3 %
- Flow rate per cycle: 126 ml
- Length of hose, e. g.: 10 m
- Output max. water @ 30 cycles 3.8 l/min
- Inlet air pressure max.: 6 bar
- Compressed air consumption: 500-900 l/min
- Innovative pump technology with self-adjusting packings
- Fast and easy maintenance of pumps through easy access to packings
- Less pulsation through quick action control valve technology in the air motor

The new EVO-Line trolley allows uncomplicated adaptation of the unit to meet your special production requirements.

The following tools and extensions are available for this:

- Boom for holding the hose package
- ATEX certified flow heater
- Different suction units (hobcock, drum and IBC)
- Different application tools

Get in touch with us if you are interested in further possibilities for adapting or expanding the unit.

# BÜFA

Composites

**BÜFA Composite Systems GmbH & Co. KG**  
Hohe Loohe 2-8  
26180 Rastede  
GERMANY

Phone +49 4402 975-0  
Fax +49 4402 975-300  
[compositesystems@buefa.de](mailto:compositesystems@buefa.de)  
[www.buefa.de](http://www.buefa.de)

A member of the BÜFA Group



[www.buefatec.de](http://www.buefatec.de)